

Art.	Forza max g	Forza trasversale g	Pressione d'esercizio bar	Consumo d'aria NI/s	Livello di rumorosità dB(A)	Peso g	Raccordo compreso art.	Ricambio gommino distanziale art.
<b>BEC 20</b>	220	145	5	2.3	66	21	00 BEC 13	00 BEC 10

N.B. L'alimentazione delle ventose BEC, deve essere effettuata con aria compressa non lubrificata, filtrazione 5 micron, secondo norma ISO 8573-1 classe 4.

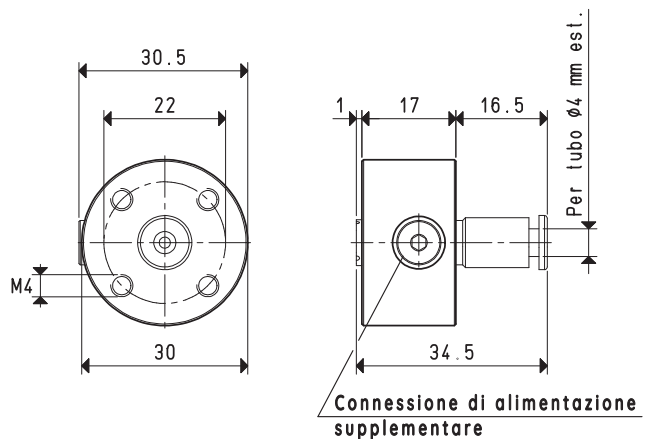

Art.	Forza max g	Forza trasversale g	Pressione d'esercizio bar	Consumo d'aria NI/s	Livello di rumorosità dB(A)	Peso g	Raccordo compreso art.	Ricambio gommino distanziale art.
<b>BEC 30</b>	380	250	5	2.5	72	31	00 BEC 13	00 BEC 10

N.B. L'alimentazione delle ventose BEC, deve essere effettuata con aria compressa non lubrificata, filtrazione 5 micron, secondo norma ISO 8573-1 classe 4.

Rapporti di trasformazione: N (newton) = Kg x 9.81 (forza di gravità); inch =  $\frac{\text{mm}}{25.4}$ ; pounds =  $\frac{\text{g}}{453.6} = \frac{\text{Kg}}{0.4536}$